

SPECIFICATION

C105-01-01B

MODEL		PH75F	PH75F	PH75F	PH75F	PH75F	PH75F	PH75F		
ITEMS		110-2	110-3	110-5	110-12	110-15	110-24	110-28		
1	Nominal Output Voltage	V	2	3	5	12	15	24	28	
2	Maximum Output Current	A	15	15	15	6.3	5	3.2	2.7	
3	Nominal Output Power	W	30	45	75	75.6	75	76.8	75.6	
4	Efficiency (Typ.) (*1)	%	66	70	81	83	84	85	85	
5	Input Voltage Range	-	82 - 185VDC							
6	Input Current (Typ.) (*1)	A	0.41	0.58	0.84	0.83	0.81	0.82	0.81	
7	Output Voltage Accuracy (*1)	%	±1							
8	Output Voltage Range (*10)	-	±20%		+20%, -60%					
9	Maximum Ripple & Noise (*9)	mV	100	100	100	150	150	240	280	
10	Maximum Line Regulation (*2)	mV	20	20	20	48	60	96	112	
11	Maximum Load Regulation (*3)	mV	40	40	40	96	120	192	224	
12	Over Current Protection (*4)	A	105% - 140%							
13	Over Voltage Protection (*5)	V	165% - 240%		125% - 145%					
14	Remote Sensing (*8)	-	Possible							
15	Remote ON/OFF Control (*8)	-	Possible (SHORT:ON OPEN:OFF)							
16	Parallel Operation (*8)	-	Possible							
17	Series Operation (*8)	-	Possible							
18	I.O.G. Signal (*8)	-	Possible (Open Collector Output)							
19	AUX - BIAS Power supply	-	7-10VDC Maximum load 10mA							
20	Operating Temperature (*6)	-	-20°C - +85°C(Baseplate) Ambient Temperature min=-20°C							
21	Operating Humidity	-	30 - 95%RH (No Dewdrop)							
22	Storage Temperature	-	-40°C - +85°C							
23	Storage Humidity	-	10 - 95%RH (No Dewdrop)							
24	Cooling (*7)	-	Conduction Cooled							
25	Temperature Coefficient (%)	-	0.02%/°C							
26	Withstand Voltage	-	Input-Baseplate : 2.5kVAC, Input-Output : 3kVAC(20mA) for 1min Output-Baseplate : 500VDC for 1min							
27	Isolation Resistance	-	More than 100M Ω at 25°C and 70%RH Output-Baseplate...500VDC							
28	Vibration	-	At No Operating, 10-55Hz (Sweep for 1min) Amplitude 0.825mm Constant (Maximum 49.0m/s <sup>2</sup> ) X,Y,Z 1h each							
29	Shock	-	196.1m/s <sup>2</sup> (In package)							
30	Weight (Typ.)	g	150							
31	Size (WxHxD)	mm	62 x 12.7 x 86 (Refer to Outline Drawing)							

=NOTES=

- \*1. At 110VDC and Maximum Output Current.
- \*2. 88 - 185VDC, Constant Load.
- \*3. No load - Full load, Constant input voltage.
- \*4. Constant current limiting with automatic recovery.
- \*5. Inverter shutdown method, Manual Reset.
- \*6. Ratings - Refer to Derating Curve on the Right.  
- Load(%) is Percent of Maximum Output Current.
- \*7. Heatsink has to be Chosen According to Instruction Manual.
- \*8. Refer to Instruction Manual.
- \*9. External Components are Needed for Operation.  
(Refer to Basic Connection and Instruction Manual)
- \*10. At 110VDC Input.(Refer to Instruction Manual.)

**\*DERATING CURVE\***

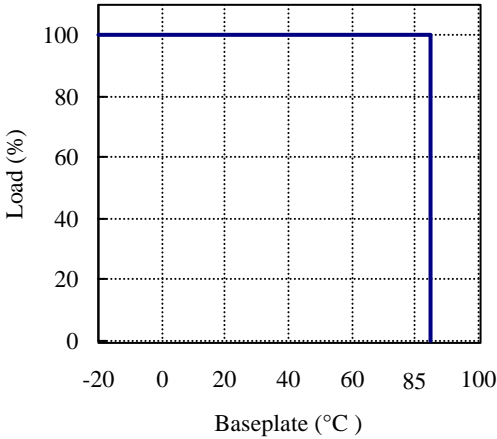

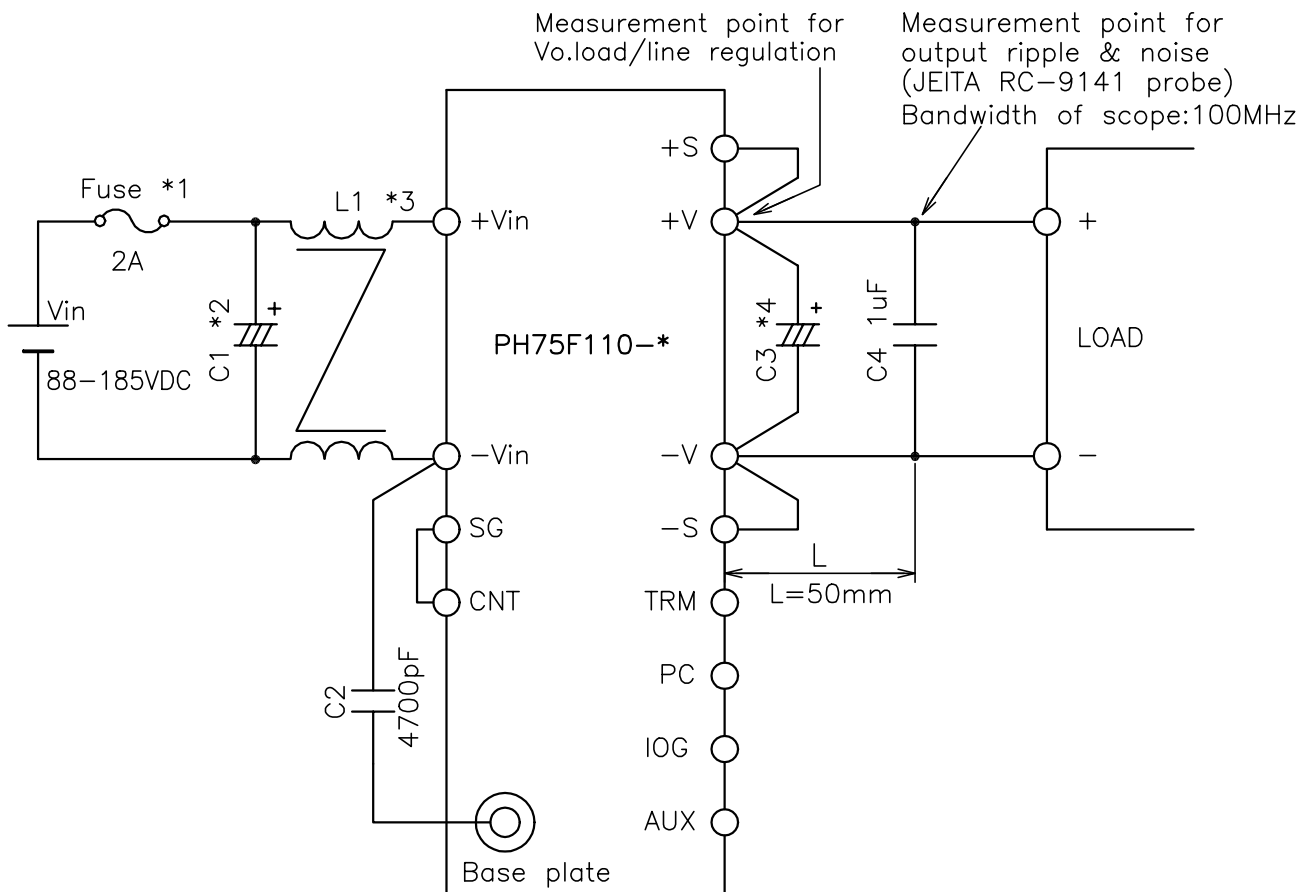

==NOTE==

- \*1. Use an external fuse of fast blow type, for each unit.
- \*2. When the input line impedance is high, insert input capacitor, C1, more than 220uF. (Refer to instruction manual)
- \*3 Put an input common mode choke coil, L1, more than 1mH.
- \*4. Put an output capacitor. (2,3V: more than 1,000uF, 5V: more than 1,000uF, 12V: more than 220uF, 15V: more than 220uF, 24V: more than 120uF, 28V: more than 100uF)  
5V: When the plate temperature is below 0°C and output voltage is below 4V, change an output capacitor,C3, to more than 2,200uF.
- \*5. Refer to instruction manual for further details.

(unit : mm)

MODEL NAME	PH75F110
<b>DENSEI-LAMBDA</b>	