

## PH50S48

## SPECIFICATIONS

C085-01-01D

ITEMS		MODEL	PH50S 48 -3.3	PH50S 48 -5	PH50S 48 -12	PH50S 48 -15	PH50S 48 -24	PH50S 48 -28
1	Nominal Output Voltage	V	3.3	5	12	15	24	28
2	Maximum Output Current	A	10	10	4.2	3.4	2.1	1.8
3	Nominal Output Power	W	33	50	50.4	51	50.4	50.4
4	Efficiency (Typ.) (*1)	%	72	80	82	83	84	84
5	Input Voltage Range	-	36 - 76VDC					
6	Input Current (Typ.) (*1)	A	0.95	1.30	1.28	1.28	1.25	1.25
7	Output Voltage Accuracy (*1)	-	±1%					
8	Output Voltage Range (*8)	-	+10%, -10% (At 48VDC Input)					
9	Maximum Ripple & Noise (*9)	mV	100	100	150	150	240	280
10	Maximum Line Regulation (*2)	mV	20	20	48	60	96	112
11	Maximum Load Regulation (*3)	mV	40	40	96	120	192	224
12	Over Current Protection (*4)	-	105 - 150%					
13	Over Voltage Protection (*5)	-	165 - 240%	125 - 145%				
14	Remote Sensing	-	-----					
15	Remote ON/OFF Control (*8)	-	Possible (SHORT:ON OPEN:OFF)					
16	Parallel Operation	-	-----					
17	Series Operation (*8)	-	Possible					
18	Operating Temperature (*6)	-	-20°C - +85°C (Baseplate) Ambient Temperature min=-20°C					
19	Operating Humidity	-	30 - 95%RH (No Dewdrop)					
20	Storage Temperature	-	-40°C - + 85°C					
21	Storage Humidity	-	10 - 95%RH (No Dewdrop)					
22	Cooling (*7)	-	Conduction Cooled					
23	Temperature Coefficient (%)	-	0.02%/°C					
24	Withstand Voltage	-	Input-Baseplate : 2.5kVAC, Input-Output : 3kVAC (20mA) for 1min, Output-Baseplate : 500VDC for 1min					
25	Isolation Resistance	-	More than 100MΩ at 25°C and 70%RH Output-Baseplate...500VDC					
26	Vibration	-	At No Operating, 10-55Hz Amplitude (Sweep for 1min) 0.825mm Constant (Maximum 49.0m/s <sup>2</sup> ) X,Y,Z 1h each					
27	Shock	-	196.1m/s <sup>2</sup> (In package)					
28	Weight (Typ.)	-	100g					
29	Size (WxHxD)	mm	41 x 12.7 x 86 (Refer to Outline Drawing)					

=NOTE=

- \*1. At 48VDC and Maximum Output Current.
- \*2. 36 - 76 VDC, Constant Load.
- \*3. No load - Full load, Constant input voltage.
- \*4. Constant current limiting with automatic recovery.
- \*5. Inverter shutdown method, Manual Reset.
- \*6. Ratings - Refer to Derating Curve on the Right.  
- Load(%) is Percent of Maximum Output Current.
- \*7. Heatsink has to be Chosen According to Instruction Manual.
- \*8. Refer to Instruction Manual.
- \*9. External Components are Needed for Operation.  
(Refer to Basic Connection and Instruction Manual)

## \*DERATING CURVE\*

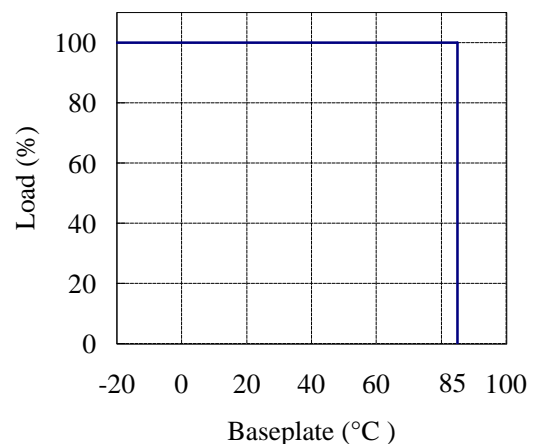

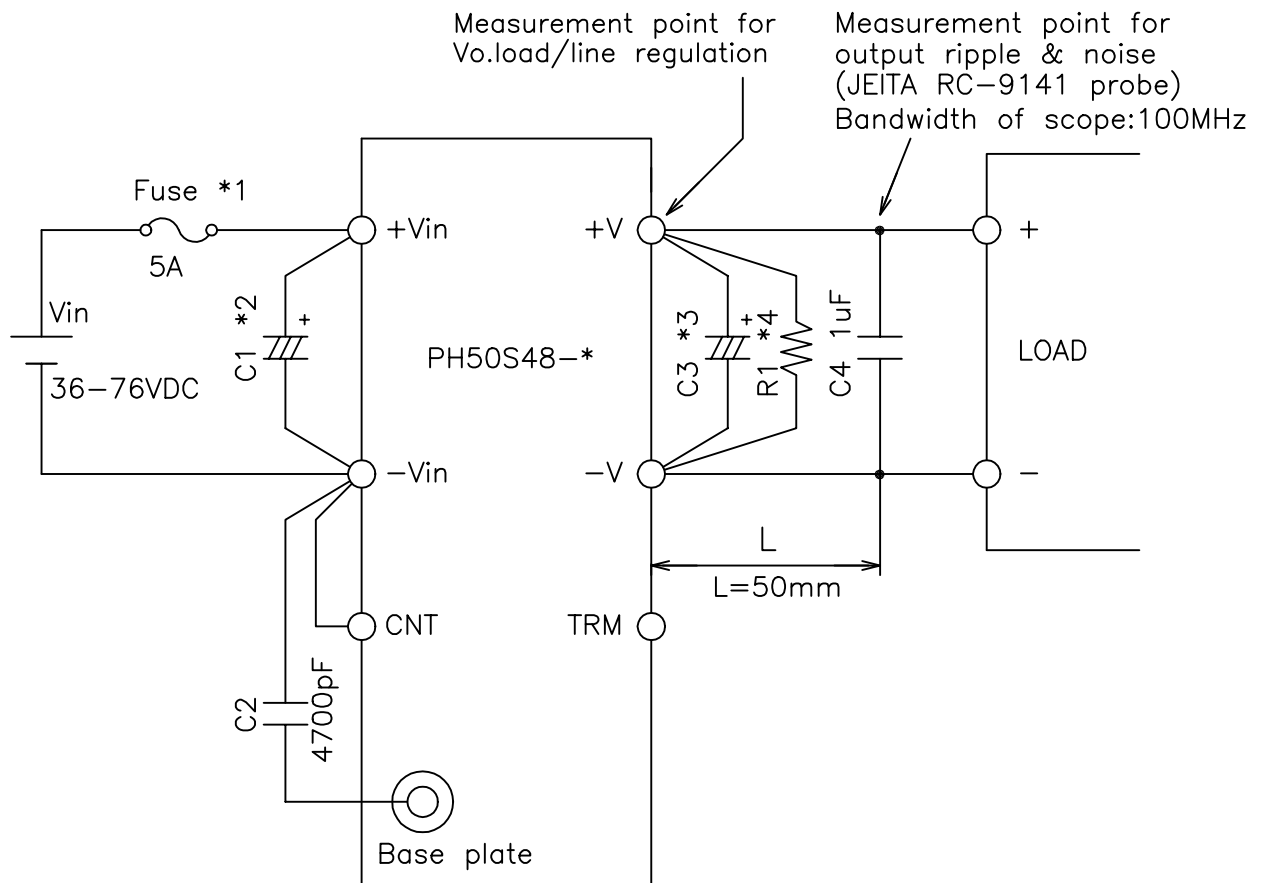

==NOTE==

- \*1. Use an external fuse of fast blow type, for each unit.
- \*2. When the input line impedance is high, insert input capacitor, C1, more than 100uF. (Refer to instruction manual)
- \*3. Put an output capacitor. (3.3V,5V: more than 470uF, 12V: more than 220uF, 15V: more than 220uF, 24V: more than 120uF, 28V: more than 100uF)
- \*4. Set the minimum load current (more than 4% of rated current) in order to prevent recurrent output voltage dropout (due to continuous skip cycle) under dynamic load conditions.
- \*5. Refer to instruction manual for further details.

(unit : mm)

MODEL NAME	PH50S48
<b>DENSEI-LAMBDA</b>	

C085-01-02E