

PAE50S48-*

C178-01-01/50-A

SPECIFICATIONS

(This specifications sheet also apply to option model /V)

MODEL		PAE50S48-1R8	PAE50S48-2R5	PAE50S48-3R3	PAE50S48-5	
1	Nominal Output Voltage	V	1.8	2.5	3.3	5
2	Maximum Output Current	A	20	18	16	10
3	Maximum Output Power	W	36	45	52.8	50
4	Efficiency (Typ.) (*1)	%	87	89	91	91
5	Input Voltage Range	-	36 - 76VDC			
6	Input Current (Typ.) (*1)	A	0.87	1.06	1.21	1.15
7	Output Voltage Accuracy (*1)	%	±1			
8	Output Voltage Range (*6)	-	-20%, +10%			±15%
9	Maximum Ripple & Noise (*6)	mV	100	100	100	100
10	Maximum Line Regulation (*2)	mV	10	10	10	10
11	Maximum Load Regulation (*3)	mV	10	10	10	10
12	Over Current Protection (*4)	-	105% - 150%			
13	Over Voltage Protection (*5)	-	115% - 135%			120% - 140%
14	Remote Sensing	-	Possible			
15	Remote ON/OFF Control	-	Possible (Short : ON, Open : OFF)			
16	Parallel Operation	-	—————			
17	Series Operation	-	Possible			
18	Operating Temperature (*7)	-	Ta= -40°C - +85°C			
19	Operating Humidity	-	5 - 95%RH (No Dewdrop)			
20	Storage Temperature	-	-40°C - +100°C			
21	Storage Humidity	-	5 - 95%RH (No Dewdrop)			
22	Cooling (*7)	-	Convection Cooled / Forced air cooled			
23	Temperature Coefficient (%)	-	Less than 0.02%/°C			
24	Withstand Voltage	-	Input-Output : 1.5kVDC for 1min			
25	Isolation Resistance	-	More than 100MΩ at 25°C and 70%RH Input-Output...500VDC			
26	Vibration	-	At No Operating, 10-55Hz (Sweep for 1min.) Amplitude 0.825mm Constant (Maximum 49.0m/s ²) X, Y, Z 1 hour each			
27	Shock	-	196.1m/s ²			
28	Weight (Typ.)	g	25			
29	Size (W×H×D)	mm	22.76×8.5×57.9 (Refer to Outline Drawing)			

=NOTES=

*1. At 48VDC, maximum output current, Air Velocity = 2m/s and Ta = +25°C.

*2. 36 - 76VDC, constant load.

*3. No load - Full load, constant input voltage.

*4. Constant current limiting.

(The unit automatically shutdown when left in OCP condition,
with the output voltage less than the LVP level.)

Auto restart option available. (Refer to C178-01-02_).

*5. Inverter shutdown method, manual reset. Auto restart option available.

*6. External components are needed for operation.

(Refer to basic connection (C178-01-02/50-_) and Instruction Manual.)

*7. Refer to derating curve (C178-01-03/50-_) and Instruction Manual.

PAE50S48-*

C178-01-02/50-A

(This specifications sheet also apply to option model /V)

1. BASIC CONNECTION

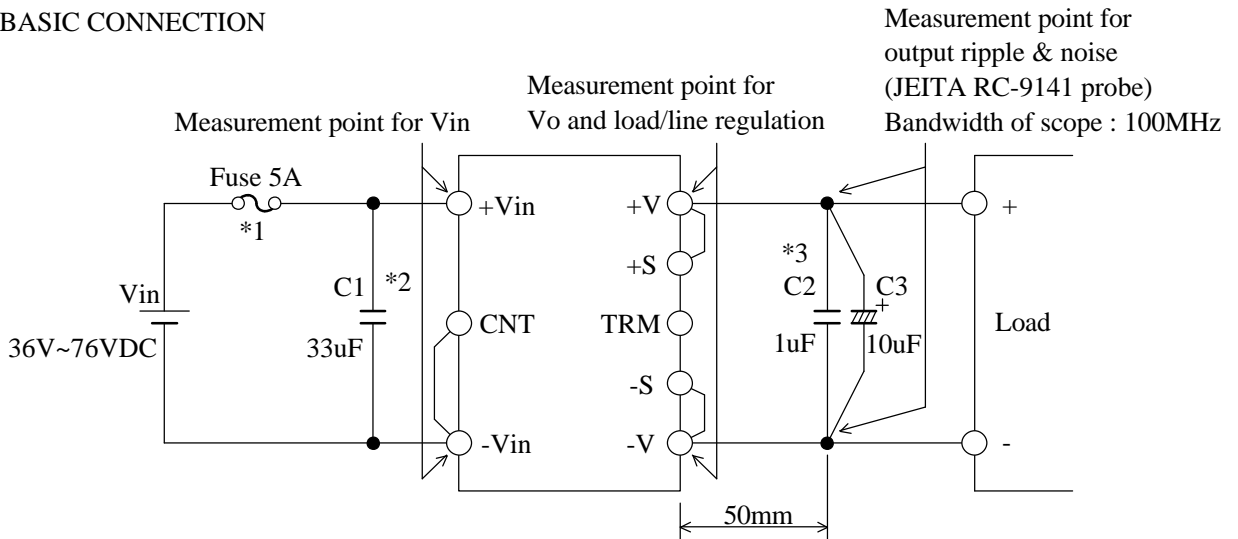

==NOTES==

- *1. Use an external fuse (fast blow type) for each unit.
- *2. Put input capacitor.
C1: 33uF ceramic capacitor or electrolytic capacitor
- *3. Put output capacitors.
C2: 1uF ceramic capacitor
C3: 10uF tantalum capacitor or electrolytic capacitor
- *4. Refer to instruction manual for further details.

2. OPTION TABLE

Option	OVP	OCP
Standard	Shut down (ON/OFF control reset or manual reset)	Shut down (ON/OFF control reset or manual reset)
/V	Auto restart	Auto restart

PAE50S48-*

C178-01-03/50

(This specifications sheet also apply to option model /V)

3. DERATING CURVE FOR STANDARD VERTICAL MOUNTING

Vin=48Vdc

PAE50S48-1R8

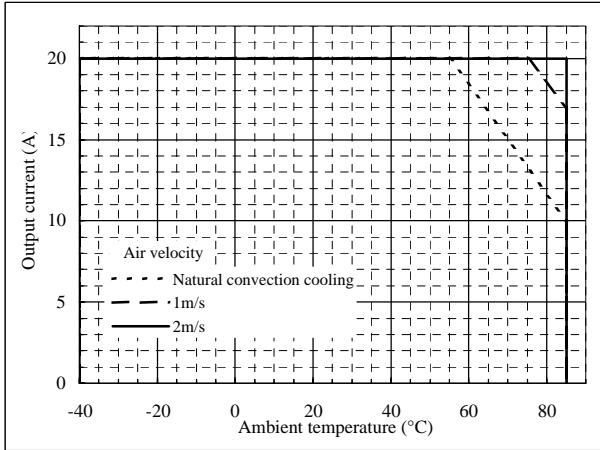

PAE50S48-2R5

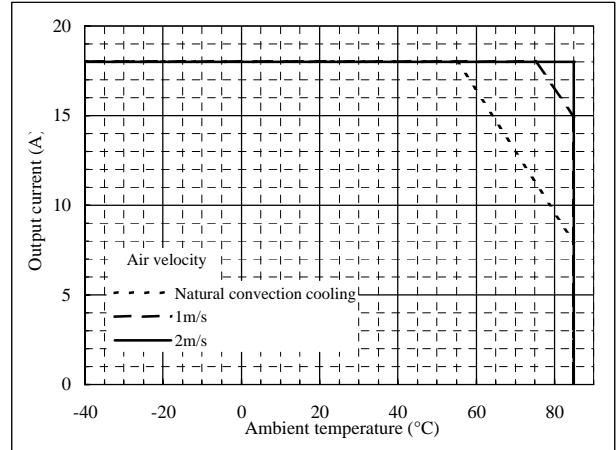

PAE50S48-3R3

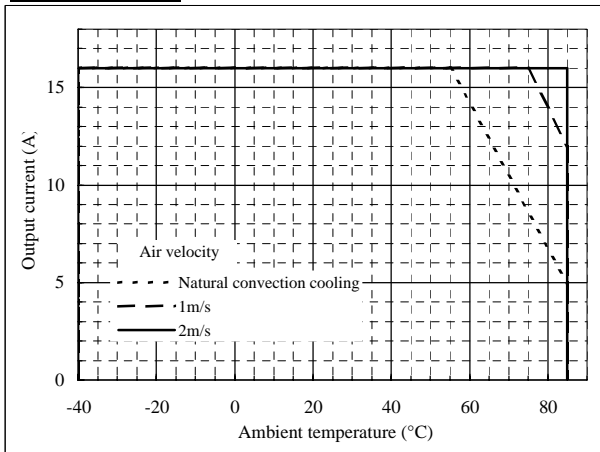

PAE50S48-5

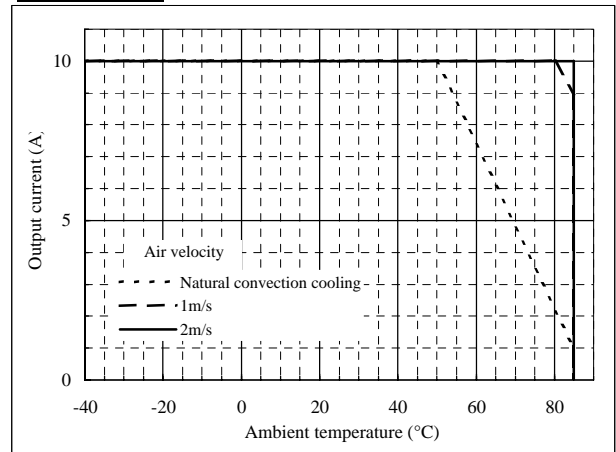

MOUNTING AND AIR DIRECTION

AIRFLOW DIRECTION FOR STANDARD VERTICAL MOUNTING

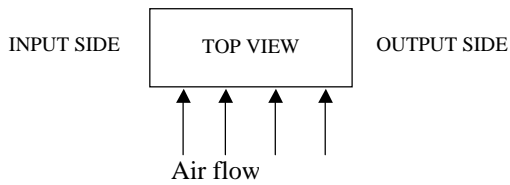

==NOTES==

*For other mounting methods, airflow direction and conditions, refer to Instruction manual