

LEAD CUT LESS THAN 3.0

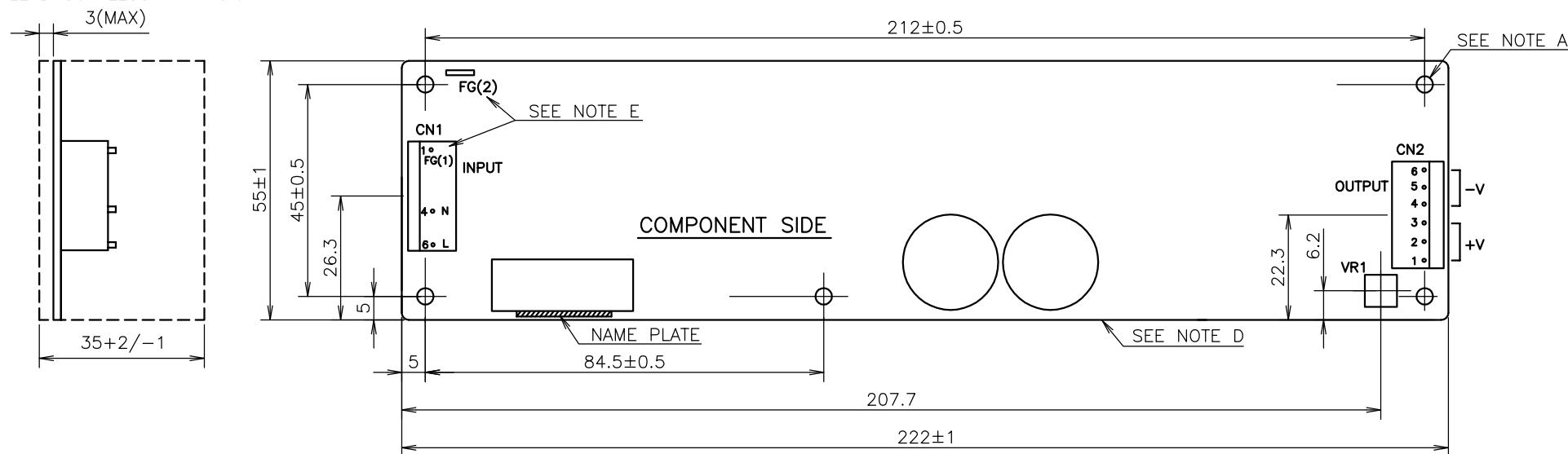

CONNECTORS USED

PART DESCRIPTION	CATALOG NO.	MANUFACTURER	QTY
PIN HEADER (INPUT SIDE CN1)	5414-30B	MOLEX	1
PIN HEADER(OUTPUT SIDE CN2)	5273-06A	MOLEX	1

MATCHING HOUSINGS & PINS.

* NOT INCLUDED WITH THE PRODUCT.

SOCKET HOUSING (CN1)	5195-06	MOLEX	1
SOCKET HOUSING (CN2)	5195-06	MOLEX	1
TERMINAL PINS (CN1, 2)	5194PBT	MOLEX	9

HAND CRIMPING TOOL: 11-26-0058

MANUFACTURER: MOLEX

NAME PLATE

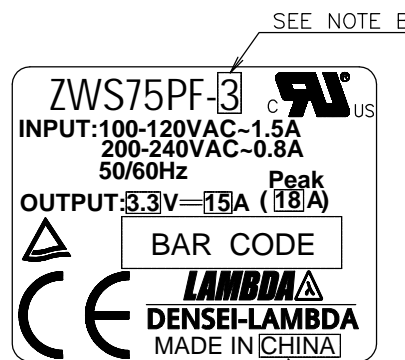

NOTES:

- A. THE 5- ϕ 3.5 HOLES ARE CUSTOMER'S CHASSIS MOUNTING HOLES. ALL MUST BE SCREWED IN ORDER TO CONFORM THE VIBRATION SPEC.
- B. MODEL NAME, NOMINAL OUTPUT VOLTAGE, AVERAGE OUTPUT CURRENT AND PEAK OUTPUT CURRENT ARE SHOWN HERE IN ACCORDANCE WITH THE SPECIFICATIONS.
- C. COUNTRY OF MANUFACTURE WILL BE SHOWN HERE.
- D. TO KEEP THE DISTANCE MORE THAN 4M/M BETWEEN PC-BOARD EDGE AND CUSTOMER'S CHASSIS.
- E. FG(1) OR FG(2) IS FOR SAFETY GROUND CONNECTION.

(unit : mm)

MODEL NAME	ZWS75PF
DENSEI-LAMBDA	

CA705-02-01E