

PVD1R5-5-1212

SPECIFICATIONS

C152-01-01A

MODEL			PVD1R5-5-1212	
ITEMS			CH1	CH2
1	Nominal Output Voltage	V	+12	-12
2	Maximum Output Current	A	0.0625	0.0625
3	Nominal Output Power	W	1.5	
4	Efficiency (Typ) (*1)	%	77	
5	Input Voltage Range	V	5 (4.5 - 9)	
6	Input Current (Typ) (*1)	A	0.39	
7	Output Voltage Accuracy (*1)	%	±5	
8	Output Voltage Range (*2)	V	+12 ~ +15	-12 ~ -15
9	Maximum Ripple & Noise (*3)	mV	120	120
10	Maximum Line Regulation (*4)	mV	50	50
11	Maximum Load Regulation (*5)	mV	600	600
12	Over Current Protection (*6)	-	Yes	
13	Over Voltage Protection	-	No	
14	Remote ON/OFF Control	-	No	
15	Parallel Operation	-	No	
16	Series Operation	-	No	
17	Operating Temperature (*7)	°C	-20 ~ +70	
18	Operating Humidity	%RH	30 ~ 90 (No dewdrop)	
19	Storage Temperature	°C	-30 ~ +85	
20	Storage Humidity	%RH	10 ~ 95 (No dewdrop)	
21	Cooling	-	Convection Cooled	
22	Temperature Coefficient	%/°C	0.02	
23	Withstand Voltage	-	Input - Output ... 500VAC 1min. (5mA)	
24	Isolation Resistance	-	More than 100Mohm at 25°C and 70% RH Input - Output ... 500VDC	
25	Vibration	-	At no operation, 10 ~ 55 ~ 10Hz (sweep for 1min.) amplitude 1.5mm constant (maximum 88.3m/s ² X, Y, Z 2h each)	
26	Shock	m/s ²	196.1	
27	Weight (Typ)	g	5	
28	Size (W x H x D)	mm	28.5 x 18 x 8.5 (Refer to Outline Drawing)	

= NOTES =

- *1 : At 5VDC input and maximum output power.
 *2 : Refer to instruction manual.
 *3 : Measured with EIAJ RC-9131 probe,
 Bandwidth of scope : 100MHz.
 *4 : From 4.5 to 9VDC input and constant load.
 *5 : From No load to Full load (balanced load)
 and constant input voltage.
 *6 : Output current limiting with automatic recovery.
 Avoid the operation longer than 30sec. with over load.
 *7 : Rating - Refer to derating curve on the right.
 - Load (%) is percentage of
 maximum output power .
 *8 : External fuse use is recommended for the operation.

Output Derating Curve

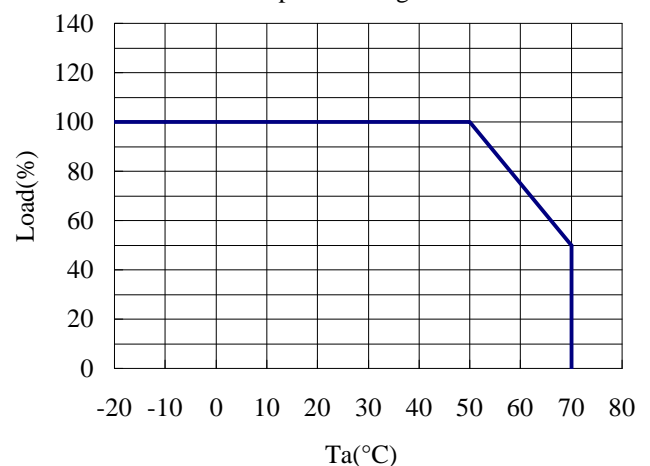

PVD1R5-5-*

C152-01-02

BASICAL CONNECTION

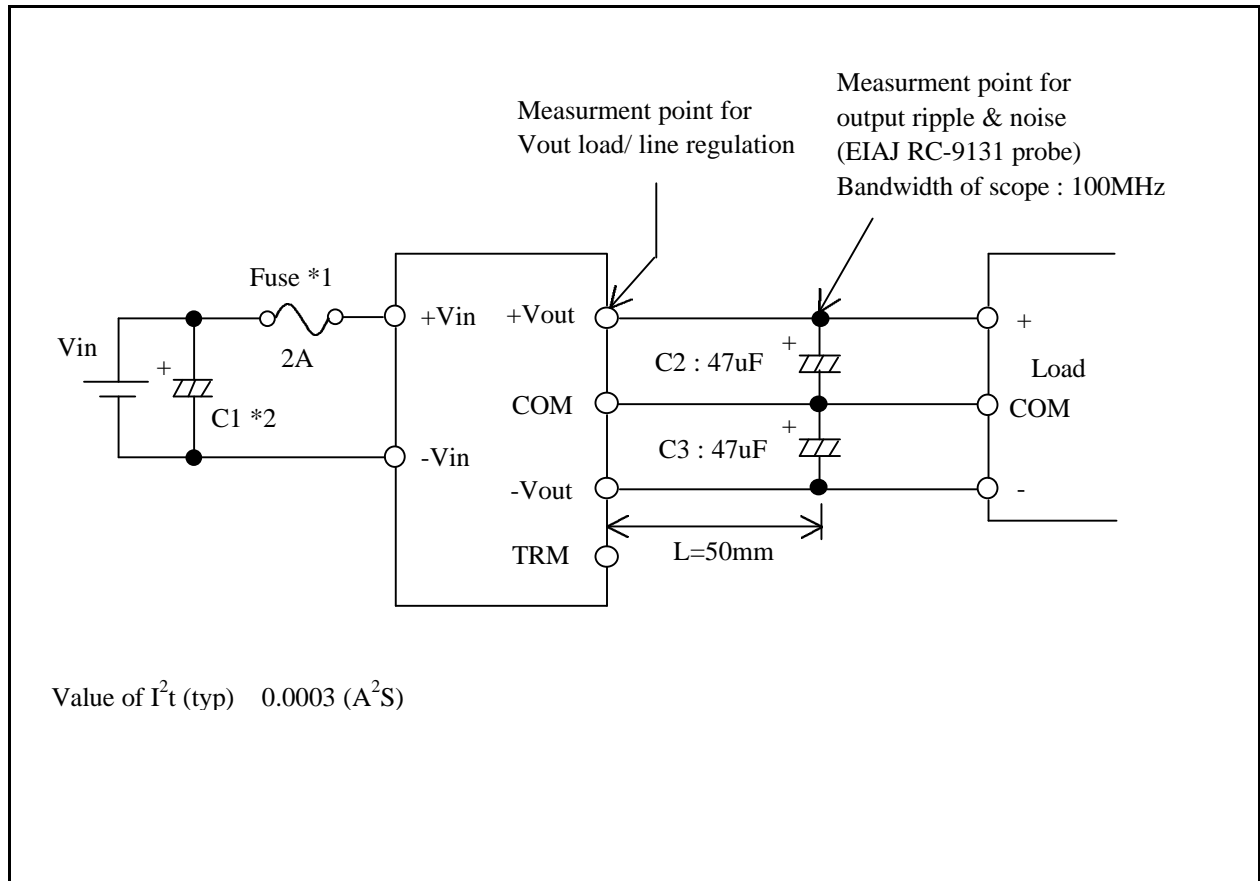

NOTE

*1 : External fuse use is recommended for the operation.

*2 : When the input line impedance is high, insert input capacitor C1 more than 150uF.
(Refer to instruction manual.)

*3 : Refer to instruction manual for further details.

PVD1R5-12-1212

SPECIFICATIONS

C153-01-01A

ITEMS			MODEL	PVD1R5-12-1212	
				CH1	CH2
1	Nominal Output Voltage	V	+12	-12	
2	Maximum Output Current	A	0.0625	0.0625	
3	Nominal Output Power	W	1.5		
4	Efficiency (Typ)	(*1) %	78		
5	Input Voltage Range	V	12 (9 - 18)		
6	Input Current (Typ)	(*1) A	0.16		
7	Output Voltage Accuracy	(*1) %	±5		
8	Output Voltage Range	(*2) V	+12 ~ +15	-12 ~ -15	
9	Maximum Ripple & Noise	(*3) mV	120	120	
10	Maximum Line Regulation	(*4) mV	50	50	
11	Maximum Load Regulation	(*5) mV	600	600	
12	Over Current Protection	(*6) -	Yes		
13	Over Voltage Protection	-	No		
14	Remote ON/OFF Control	-	No		
15	Parallel Operation	-	No		
16	Series Operation	-	No		
17	Operating Temperature	(*7) °C	-20 ~ +70		
18	Operating Humidity	%RH	30 ~ 90 (No dewdrop)		
19	Storage Temperature	°C	-30 ~ +85		
20	Storage Humidity	%RH	10 ~ 95 (No dewdrop)		
21	Cooling	-	Convection Cooled		
22	Temperature Coefficient	%/°C	0.02		
23	Withstand Voltage	-	Input - Output ... 500VAC 1min. (5mA)		
24	Isolation Resistance	-	More than 100Mohm at 25°C and 70% RH Input - Output ... 500VDC		
25	Vibration	-	At no operation, 10 ~ 55 ~ 10Hz (sweep for 1min.) amplitude 1.5mm constant (maximum 88.3m/s ² X, Y, Z 2h each)		
26	Shock	m/s ²	196.1		
27	Weight (Typ)	g	5		
28	Size (W x H x D)	mm	28.5 x 18 x 8.5 (Refer to Outline Drawing)		

= NOTES =

- *1 : At 12VDC input and maximum output power.
 *2 : Refer to instruction manual.
 *3 : Measured with EIAJ RC-9131 probe,
 Bandwidth of scope : 100MHz.
 *4 : From 9 to 18VDC input and constant load.
 *5 : From No load to Full load (balanced load)
 and constant input voltage.
 *6 : Output current limiting with automatic recovery.
 Avoid the operation longer than 30sec. with over load.
 *7 : Rating - Refer to derating curve on the right.
 - Load (%) is percentage of
 maximum output power .
 *8 : External fuse use is recommended for the operation.

Output Derating Curve

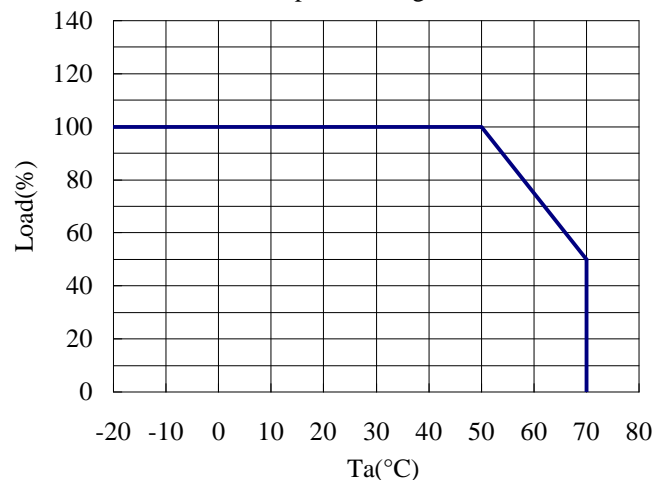

PVD1R5-12-*

C153-01-02

BASIC CONNECTION

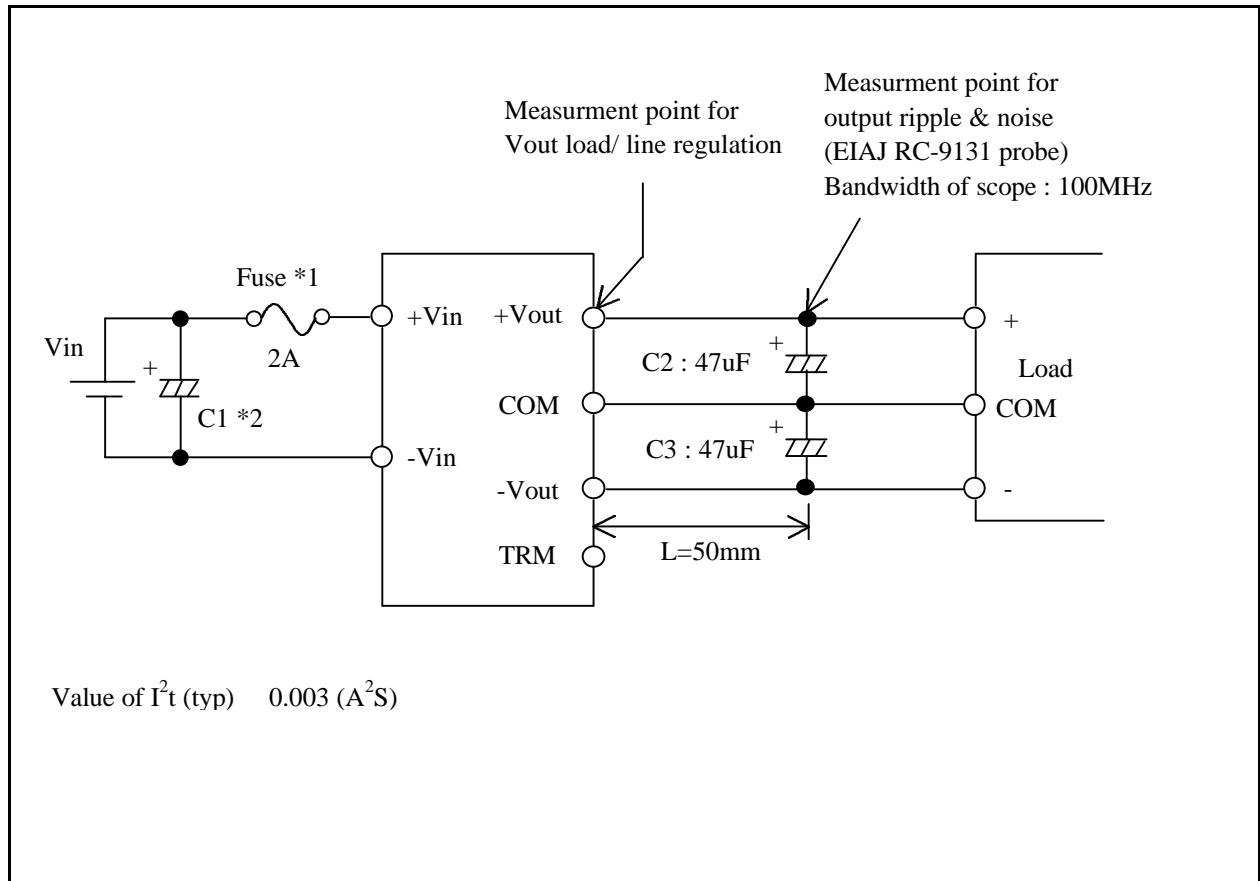

NOTE

*1 : External fuse use is recommended for the operation.

*2 : When the input line impedance is high, insert input capacitor C1 more than 47uF.
(Refer to instruction manual.)

*3 : Refer to instruction manual for further details.

PVD1R5-24-1212**SPECIFICATIONS**

C154-01-01A

ITEMS			MODEL	PVD1R5-24-1212	
				CH1	CH2
1	Nominal Output Voltage	V	+12	-12	
2	Maximum Output Current	A	0.0625	0.0625	
3	Nominal Output Power	W	1.5		
4	Efficiency (Typ) (*1)	%	78		
5	Input Voltage Range	V	24 (18 - 36)		
6	Input Current (Typ) (*1)	A	0.08		
7	Output Voltage Accuracy (*1)	%	±5		
8	Output Voltage Range (*2)	V	+12 ~ +15	-12 ~ -15	
9	Maximum Ripple & Noise (*3)	mV	120	120	
10	Maximum Line Regulation (*4)	mV	50	50	
11	Maximum Load Regulation (*5)	mV	600	600	
12	Over Current Protection (*6)	-	Yes		
13	Over Voltage Protection	-	No		
14	Remote ON/OFF Control	-	No		
15	Parallel Operation	-	No		
16	Series Operation	-	No		
17	Operating Temperature (*7)	°C	-20 ~ +70		
18	Operating Humidity	%RH	30 ~ 90 (No dewdrop)		
19	Storage Temperature	°C	-30 ~ +85		
20	Storage Humidity	%RH	10 ~ 95 (No dewdrop)		
21	Cooling	-	Convection Cooled		
22	Temperature Coefficient	%/°C	0.02		
23	Withstand Voltage	-	Input - Output ... 500VAC 1min. (5mA)		
24	Isolation Resistance	-	More than 100Mohm at 25°C and 70% RH Input - Output ... 500VDC		
25	Vibration	-	At no operation, 10 ~ 55 ~ 10Hz (sweep for 1min.) amplitude 1.5mm constant (maximum 88.3m/s ² X, Y, Z 2h each)		
26	Shock	m/s ²	196.1		
27	Weight (Typ)	g	5		
28	Size (W x H x D)	mm	28.5 x 18 x 8.5 (Refer to Outline Drawing)		

= NOTES =

- *1 : At 24VDC input and maximum output power.
- *2 : Refer to instruction manual.
- *3 : Measured with EIAJ RC-9131 probe,
Bandwidth of scope : 100MHz.
- *4 : From 18 to 36VDC input and constant load.
- *5 : From No load to Full load (balanced load)
and constant input voltage.
- *6 : Output current limiting with automatic recovery.
Avoid the operation longer than 30sec. with over load.
- *7 : Rating - Refer to derating curve on the right.
- Load (%) is percentage of
maximum output power .
- *8 : External fuse use is recommended for the operation.

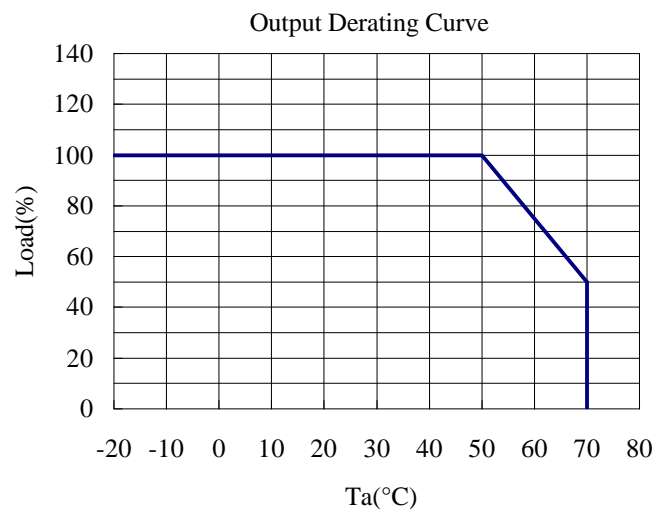

PVD1R5-24-*

C154-01-02

BASICAL CONNECTION

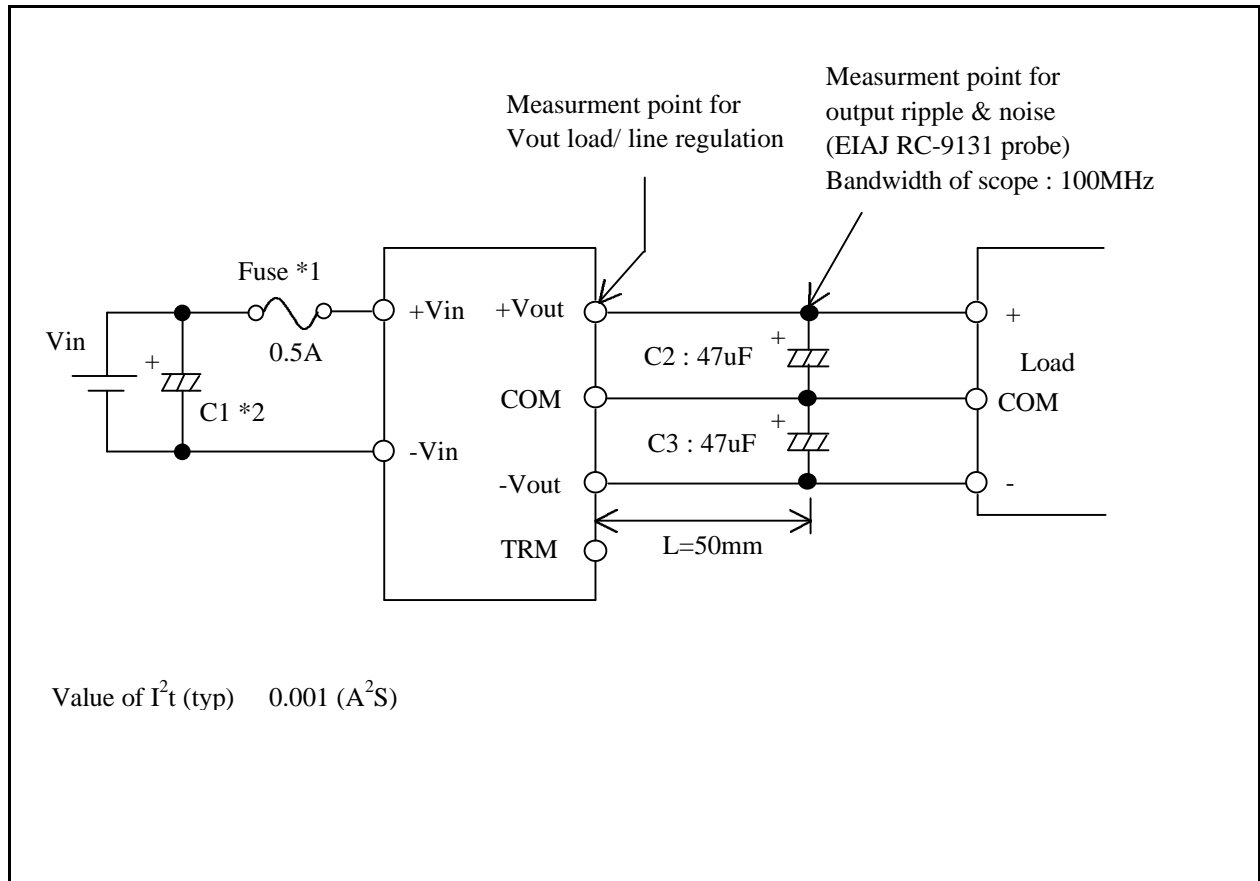

NOTE

*1 : External fuse use is recommended for the operation.

*2 : When the input line impedance is high, insert input capacitor C1 more than 10uF.
(Refer to instruction manual.)

*3 : Refer to instruction manual for further details.

PVD1R5-48-1212

SPECIFICATIONS

C155-01-01A

MODEL			PVD1R5-48-1212	
ITEMS			CH1	CH2
1	Nominal Output Voltage	V	+12	-12
2	Maximum Output Current	A	0.0625	0.0625
3	Nominal Output Power	W	1.5	
4	Efficiency (Typ) (*1)	%	78	
5	Input Voltage Range	V	48 (36 - 72)	
6	Input Current (Typ) (*1)	A	0.04	
7	Output Voltage Accuracy (*1)	%	±5	
8	Output Voltage Range (*2)	V	+12 ~ +15	-12 ~ -15
9	Maximum Ripple & Noise (*3)	mV	120	120
10	Maximum Line Regulation (*4)	mV	50	50
11	Maximum Load Regulation (*5)	mV	600	600
12	Over Current Protection (*6)	-	Yes	
13	Over Voltage Protection	-	No	
14	Remote ON/OFF Control	-	No	
15	Parallel Operation	-	No	
16	Series Operation	-	No	
17	Operating Temperature (*7)	°C	-20 ~ +70	
18	Operating Humidity	%RH	30 ~ 90 (No dewdrop)	
19	Storage Temperature	°C	-30 ~ +85	
20	Storage Humidity	%RH	10 ~ 95 (No dewdrop)	
21	Cooling	-	Convection Cooled	
22	Temperature Coefficient	%/°C	0.02	
23	Withstand Voltage	-	Input - Output ... 500VAC 1min. (5mA)	
24	Isolation Resistance	-	More than 100Mohm at 25°C and 70% RH Input - Output ... 500VDC	
25	Vibration	-	At no operation, 10 ~ 55 ~ 10Hz (sweep for 1min.) amplitude 1.5mm constant (maximum 88.3m/s ² X, Y, Z 2h each)	
26	Shock	m/s ²	196.1	
27	Weight (Typ)	g	5	
28	Size (W x H x D)	mm	28.5 x 18 x 8.5 (Refer to Outline Drawing)	

= NOTES =

- *1 : At 48VDC input and maximum output power.
- *2 : Refer to instruction manual.
- *3 : Measured with EIAJ RC-9131 probe,
Bandwidth of scope : 100MHz.
- *4 : From 36 to 72VDC input and constant load.
- *5 : From No load to Full load (balanced load)
and constant input voltage.
- *6 : Output current limiting with automatic recovery.
Avoid the operation longer than 30sec. with over load.
- *7 : Rating - Refer to derating curve on the right.
- Load (%) is percentage of
maximum output power .
- *8 : External fuse use is recommended for the operation.

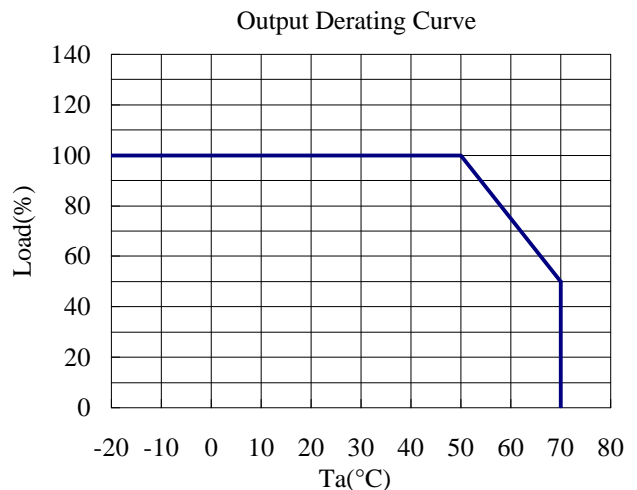

PVD1R5-48-*

C155-01-02

BASICAL CONNECTION

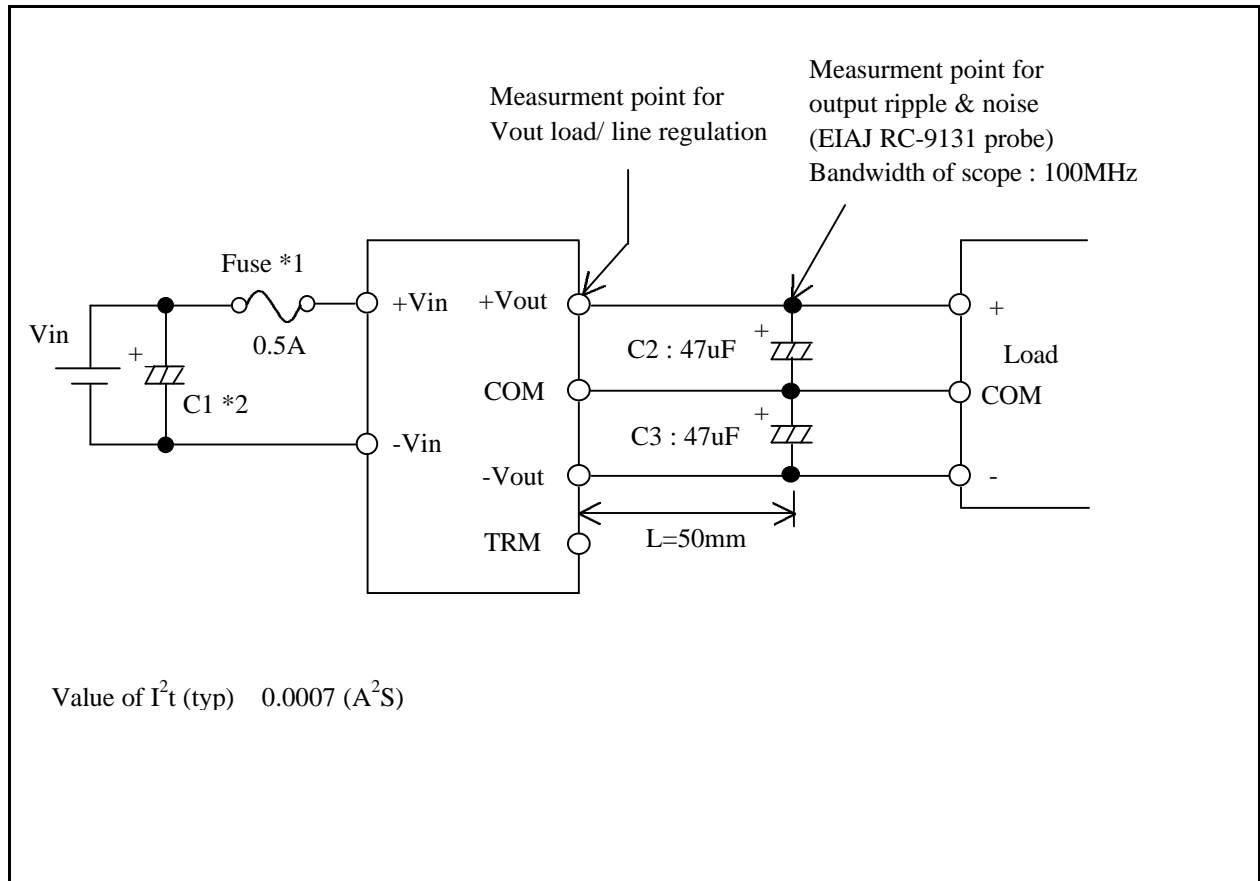

NOTE

*1 : External fuse use is recommended for the operation.

*2 : When the input line impedance is high, insert input capacitor C1 more than 2.2uF.
(Refer to instruction manual.)

*3 : Refer to instruction manual for further details.